

TOTAL PROPOSE FAR SF: 3453

LOT OCC: %75 ALLOWABLE PROPOSE %72.2

FAR Summery IZ 3.0 3456 sf. allowable

PARKING N/A
GREEN AREA PROPOSED 360 sf.

CELLAR	N/A	N/A
1st FLOOR		817 sf.
2nd FLOOR		749 sf.
3rd FLOOR		749 sf.
4th FLOOR		791 sf.
PENTHOUSE		347 sf.
TOTAL PROPOSED		3453 sf.

TOTAL UNIT NO. 5 =4 + 1 IZ unit

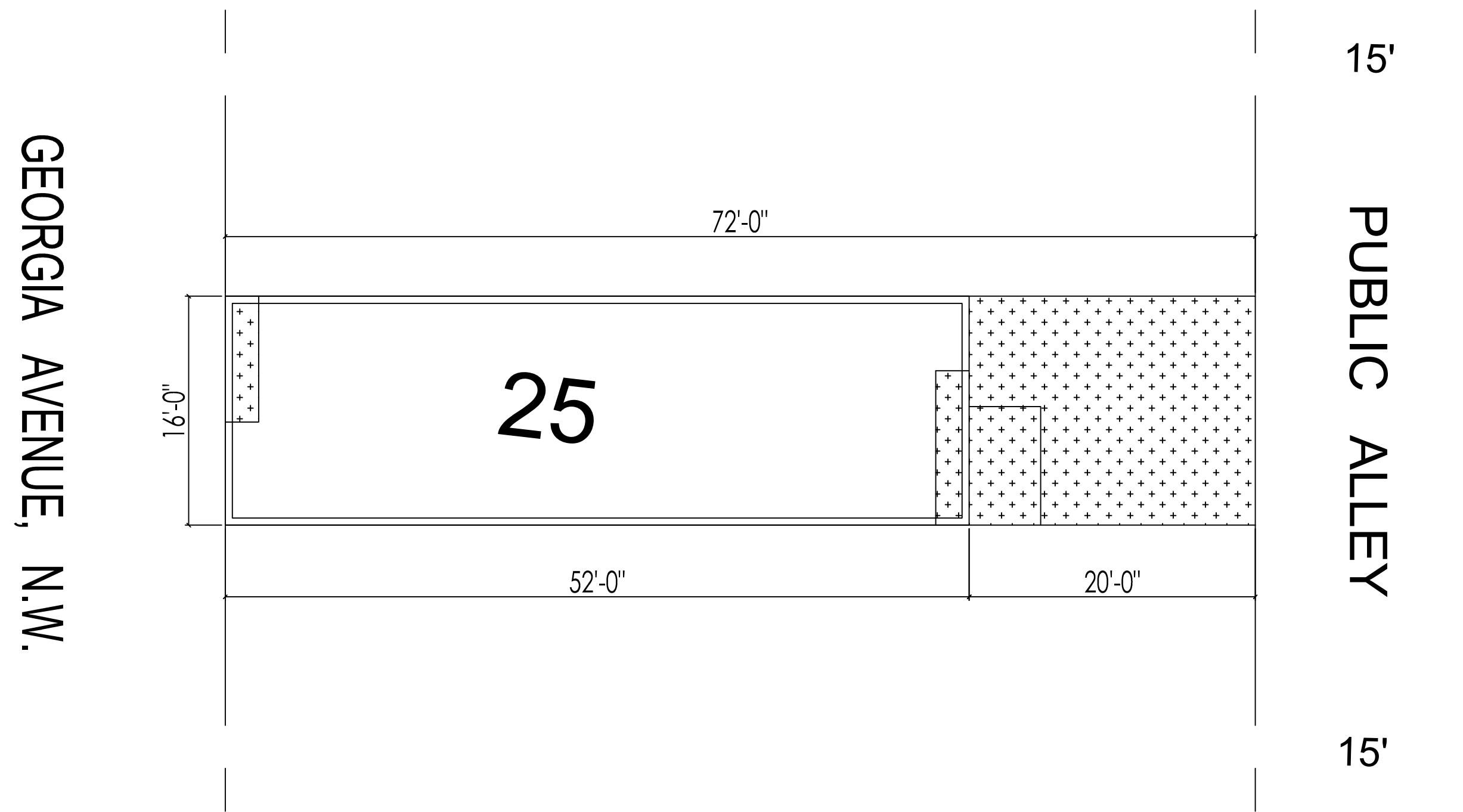

PLAT

SC 1/8" = 1'

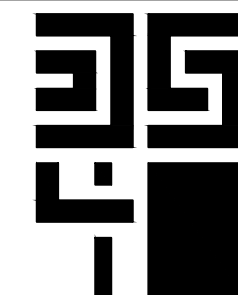

DESIGN STUDIO04

20417 Alderleaf Terrace
Germantown MD 20874
T 301.461.7246 / F
company@ds4.co